

Test burner PB2

12.02

DUNGS[®]
Combustion Controls



Technical description

The Dungs test burner PB2 with push button cock is flashback-proof.

Press the push-button 1 to release gas supply. The gas flow takes the required air in through the hole in the burner tube 2.

The gas-air mixture is fed to the burner head 3 and manually ignited at the outlet opening.

The gas supply remains open when the push-button is pressed and is immediately interrupted after the pushbutton is released.

Application

The universal gas test burner is used in firing systems for steam boilers and for venting gas regulator trains.

Test burners are required in compliance with the requirements of TRD 412 (5.95).

The PB2 is suitable for gases of families 1, 2 and 3.

Approvals

Push-button valve 1:

EC type testing certificate as per:

- EC-Gas Appliances Regulation

**Test burner
PB2**



Specifications

Connection	Standard R ½ Option Rp ½
Max. operating pressure	Test burner: 500 mbar (50 kPa) Push-button valve: 5 bar (500 kPa)
Min. pressure	Functionally reliable from a minimum pressure of 0.5 mbar (50 Pa)
Ambient temperature	-15 °C to +70 °C
Installation position	Vertically upright

Order details	Type	Order No.
Test burner (complete with nozzle)	PB2 for natural gas; R ½	273 370
	PB2 for LPG; R ½	273 384
	PB2 for town gas; R ½ not approved for Austria	273 383
Nozzles (spare / replacement)	Natural gas Nozzle, 1.8 dia.	033 217
	LPG Nozzle 2a, 0.9 dia.	084 954
	Town gas Nozzle, 1.8 dia.	033 217
Sealing ring		227 125

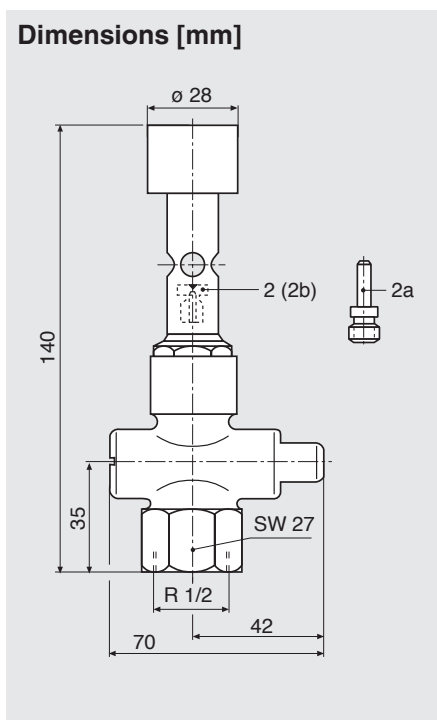

We reserve the right to make any changes in the interest of technical progress.

Head Offices and Factory
Karl Dungs GmbH & Co. KG
Karl-Dungs-Platz 1
D-73660 Urbach, Germany
Telephone +49 (0)7181-804-0
Fax +49 (0)7181-804-166

Postal address
Karl Dungs GmbH & Co. KG
Postfach 12 29
D-73602 Schorndorf, Germany
e-mail info@dungs.com
Internet www.dungs.com